

SS3A - SS3M

PRV : 50 - 1000 Volts
Io : 3.0 Amperes

FEATURES :

- * High current capability
- * High surge current capability
- * High reliability
- * Low reverse current
- * Low forward voltage drop
- * Super fast recovery time
- * Pb / RoHS Free

MECHANICAL DATA :

- * Case : SMC Molded plastic
- * Epoxy : UL94V-O rate flame retardant
- * Lead : Lead Formed for Surface Mount
- * Polarity : Color band denotes cathode end
- * Mounting position : Any
- * Weight : 0.21 gram

SURFACE MOUNT SUPER FAST RECTIFIERS

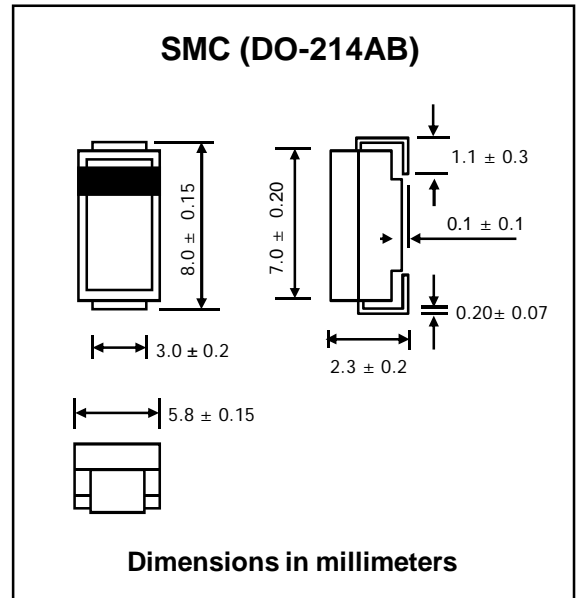

MAXIMUM RATINGS AND ELECTRICAL CHARACTERISTICS

Rating at 25 °C ambient temperature unless otherwise specified.
 Single phase, half wave, 60 Hz, resistive or inductive load.
 For capacitive load, derate current by 20%.

RATING	SYMBOL	SS3A	SS3B	SS3C	SS3D	SS3E	SS3G	SS3J	SS3K	SS3M	UNIT
Maximum Recurrent Peak Reverse Voltage	V _{RRM}	50	100	150	200	300	400	600	800	1000	V
Maximum RMS Voltage	V _{RMS}	35	70	105	140	210	280	420	560	700	V
Maximum DC Blocking Voltage	V _{DC}	50	100	150	200	300	400	600	800	1000	V
Maximum Average Forward Current 0.375"(9.5mm) Lead Length Ta = 55 °C	I _{F(AV)}	3.0									A
Maximum Peak Forward Surge Current 8.3ms Single half sine wave Superimposed on rated load (JEDEC Method)	I _{FSM}	125									A
Maximum Peak Forward Voltage at I _F = 3.0 A	V _F	0.95			1.7			4.0			V
Maximum DC Reverse Current T _j = 25 °C at Rated DC Blocking Voltage T _j = 100 °C	I _R	10									μA
	I _{R(H)}	500									
Maximum Reverse Recovery Time (Note 1)	T _{rr}	35									ns
Typical Junction Capacitance (Note 2)	C _J	50									pf
Junction Temperature Range	T _J	- 65 to + 150									°C
Storage Temperature Range	T _{STG}	- 65 to + 150									°C

Notes :

- (1) Reverse Recovery Test Conditions : I_F = 0.5 A, I_R = 1.0 A, I_{rr} = 0.25 A.
- (2) Measured at 1.0 MHz and applied reverse voltage of 4.0 V_{dc}

RATING AND CHARACTERISTIC CURVES (SS3A - SS3M)

FIG.1 - REVERSE RECOVERY TIME CHARACTERISTIC AND TEST CIRCUIT DIAGRAM

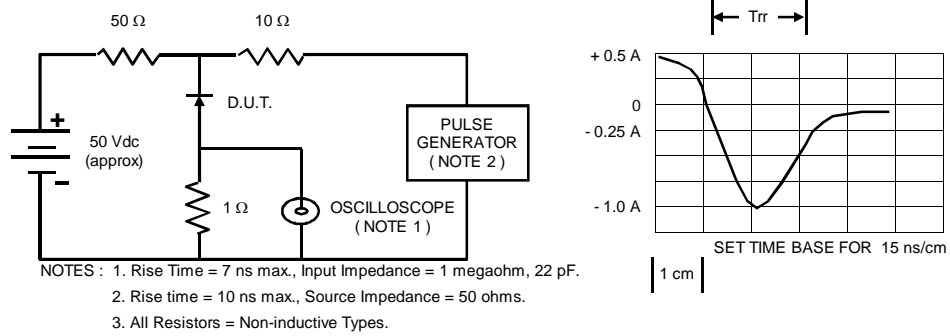

FIG.2 - DERATING CURVE FOR OUTPUT RECTIFIED CURRENT

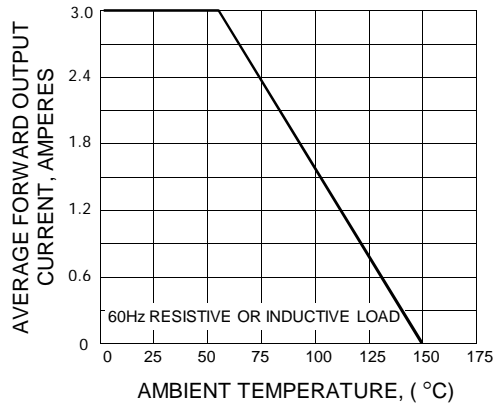

FIG.3 - MAXIMUM NON-REPETITIVE PEAK FORWARD SURGE CURRENT

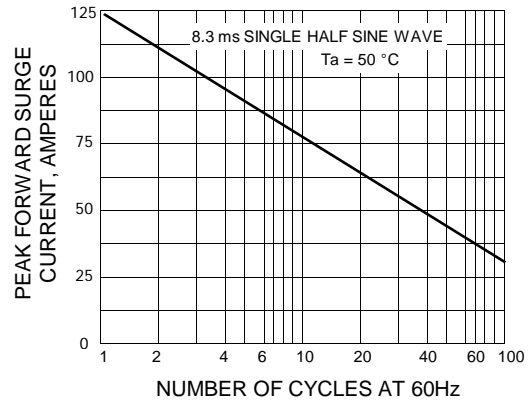

FIG.4 - TYPICAL FORWARD CHARACTERISTICS

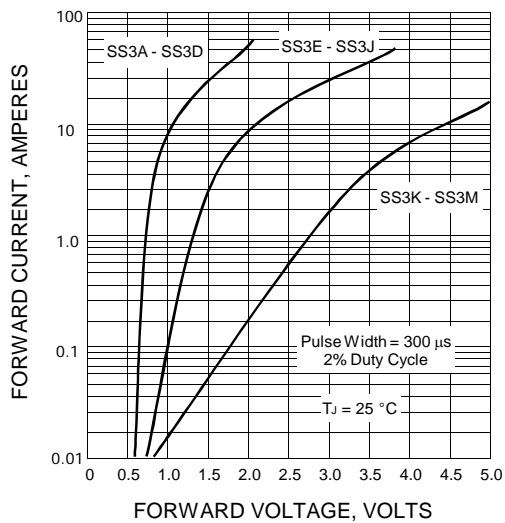

FIG.5 - TYPICAL REVERSE CHARACTERISTICS

